



**BIGFOOT**  
SYSTEMS® **The Original.**



# Installation Manual

**Bigfoot Systems Inc.**  
[www.bigfootsystems.com](http://www.bigfootsystems.com)  
EM [info@bigfootsystems.com](mailto:info@bigfootsystems.com)

6750 Highway 3, Martin's Point  
RR #2, Mahone Bay, Nova Scotia  
Canada B0J 2E0

TF 1-800-934-0393  
PH (902) 627-1600  
FX (902) 627-1700

Bigfoot Systems Inc.  
 RR#2, Mahone Bay  
 6750 Hwy. #3, Martins Point  
 Nova Scotia, Canada B0J 2E0

BIGFOOT SYSTEMS® FOOTING FORMS  
 U.S. Pat. No. 29/063,625, U.S. Pat. No. 5,785,459; U.S. Des. Pat. No. 393,474; U.S. Pat. No. 6,840,491



Canadian Construction Materials Centre  
 CCMC 12839-R



ICC Evaluation Services Inc.  
 ESR - 2148

## INSTALLATION MANUAL

### 1.0 INTRODUCTION

The Bigfoot Systems® Footing Forms come in four sizes: Model BF20, Model BF24, Model BF28 and Model BF36. Each model accepts various diameter construction tubes, as per Table 1, Figure 1.

TABLE 1

Ring Diameter	BF20 in. (cm)	BF24 in. (cm)	BF28 in. (cm)	BF36 in. (cm)	Ring Height in. (cm)	BF20 in. (cm)	BF24 in. (cm)	BF28 in. (cm)	BF36 in. (cm)
D1	5.5 (13.97)	7.5 (19.05)	9.5 (24.13)	12 (30.48)	H1	18.00 (39.37)	18.75 (47.63)	18.75 (47.63)	23.0 (58.42)
D2	6.02 (15.29)	8.02 (20.37)	10.02 (25.45)	14 (35.56)	H2	17.00 (43.18)	17.625 (44.77)	17.625 (44.77)	20.5 (52.07)
D3	6.48 (16.46)	8.42 (21.39)	10.42 (26.47)	16 (40.64)	H3	16.00 (40.64)	16.5 (41.91)	16.5 (41.91)	18.0 (45.72)
D4	7.50 (19.05)	9.5 (24.13)	11.5 (29.21)	18 (45.72)	H4	15.00 (38.10)	15.35 (39.05)	15.375 (39.05)	15.5 (39.37)
D5	8.02 (20.37)	10.02 (25.45)	12.02 (30.53)		H5	14.00 (35.56)	14.25 (36.20)	14.25 (36.20)	
D6	8.42 (21.39)	10.42 (26.47)	12.42 (31.55)		H6	13.00 (33.02)	13.125 (33.34)	13.125 (33.34)	
D7	21.5 (54.61)	25.2 (64.01)	29.6 (75.18)	36.40 (92.42)	Wall Thickness	0.105 – 0.075 (0.2667 - 0.1905)	0.105 – 0.075 (0.2667 - 0.1905)	0.105 – 0.080 (0.2667 – 0.2032)	0.160 (+/- 0.040) 0.4064 (+/- 0.1016)
D0	20 (50.80)	24 (60.96)	28 (71.12)	36 (91.44)					

FIGURE 1

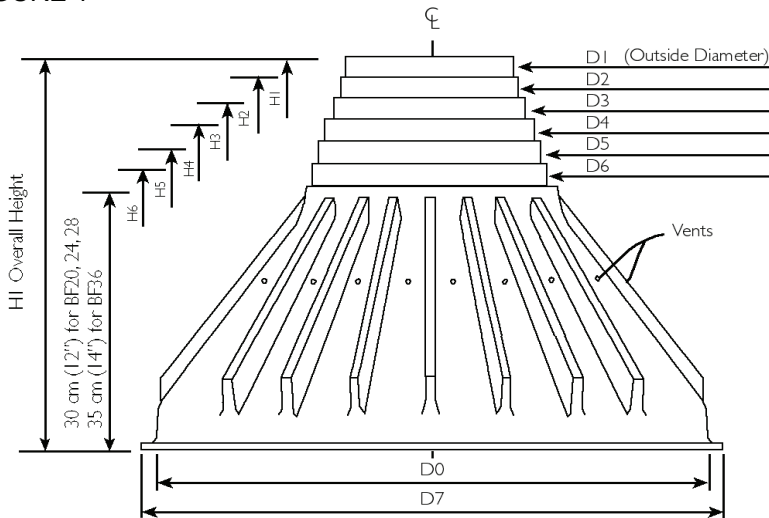

Figure 1. Bigfoot Systems® Footing Forms

## 1.1 ABOVE GROUND APPLICATION (DRAWING BFS-101)

1. After determining which Model Bigfoot Systems® Footing Form and construction tube size is required for your application, excess rings above the ring diameter required MUST be removed with a utility knife, hand snips or saw and discarded. {example: if you are using a 10 in. (25.40 cm) medium construction tube with the Model BF24 remove excess plastic at top of medium 10 in. (25.40 cm) ring thereby discarding the 10 in. (25.40 cm) small and 8 in. (20.30 cm) small, medium and large rings.}
2. Attach the required length of construction tube to the Bigfoot with a minimum of four 3/4 in. - 1 in. long (19.1 mm – 25.4 mm) #8 wood screws.
3. If the construction tube frays inward when cut with a handsaw remove the excess frayed tube material with a utility knife for ease of application to the Bigfoot footing form.
4. Drill 3/8 in. (9.53 mm) holes on a 45-degree angle in the footing form as indicated by the markings on the flange area at each rib location to accept a minimum of 12 in. (30.48 cm) spikes.
5. Place the Bigfoot on undisturbed soil and drive spikes at a 45 degree angle inwards to prevent Bigfoot from rising when concrete is being poured. If the soil is such that the spikes cannot resist the upward pressure caused by the concrete being poured into the footing form then alternative methods such as sandbags or backfill must be used to hold the footing form in place.
6. If the height of the construction tube exceeds 3 ft. (0.91 m) above ground the tube must then be braced in accordance with Section 3.0, “Bracing” in the Installation Manual (See Drawing BFS-103).
7. The total combined height of the Bigfoot Systems® must not exceed 5 ft. (1.52 m).
8. When ready to pour use another Bigfoot inverted on top of the construction tube to act as a funnel.
9. The Model BF36 is not recommended for above ground applications.

## 1.2 BELOW GRADE APPLICATION MODELS BF20, BF24 AND BF28 (DRAWING BFS-102)

1. After determining which Model Bigfoot Systems® Footing Form and construction tube size is required for your application, excess rings above the ring diameter required must be removed with a utility knife, hand snips or saw and discarded. {example: if you are using a 10 in. (25.40 cm) medium construction tube with the Model BF24 remove excess plastic at top of medium 10 in. (25.40 cm) ring thereby discarding the 10 in. (25.40 cm) small and 8 in. (20.30 cm) small, medium and large rings.}
2. Attach the required length of construction tube to Bigfoot footing form with a minimum of four 3/4 in. - 1 in. long (19.1 mm - 2.54 cm) wood screws.
3. If the construction tube frays inward when cut with a handsaw, remove excess frayed tube material with a utility knife for ease of application.
4. Place the Bigfoot in the excavation on top of undisturbed soil or 4 in. - 6 in. (10.16 - 15.24 cm) of compacted crushed stone or gravel, level and have inspected by a Building Inspector if necessary, then backfill in accordance with section 4.0 “Backfill for Below Grade Applications”. The Model BF36 footing form must be placed on level undisturbed soil or on 4 to 6 inches (102 to 152 mm) of compacted crushed stone or gravel. Align the Bigfoot and construction tube with batter board lines, plum and brace as shown in (Drawing BFS-103).
5. When backfilling avoid dropping or placing heavy rocks or heavy wet clay on Bigfoot Systems® footing form.
6. If the tube height above grade exceeds 3 ft. (0.91 m) the tube must then be braced in accordance with Section 3.0, “Bracing” in the Installation Manual (See Drawing BFS-103).

## 1.3 BELOW GRADE APPLICATION Model BF36 (DRAWING BFS-102)

1. See #1, 2, and 3 Below Grade Application for the Models BF20, BF24 and BF28
2. Align batter board lines, plum and brace as shown in Figure 2- Typical Bracing during construction.
3. Backfill over the footing form to a minimum height of 2 feet (610mm) from the bottom of the footing form and compacted with a mechanical compactor. Continue backfill in 8- to 12-inch (203mm) lifts to a maximum height of 5 feet. Compaction must be carried out between each lift. The concrete must be placed in lifts that are 10 to 16 inches (254 to 406 mm) in height, with the concrete being consolidated after each lift, as per previous instructions.

## 7. Height Restrictions

- a) The total combined height of Bigfoot Systems® Footing Forms must not exceed 13 ft. (3.96 m).
  - b) The maximum tube height for the 6 in. (15.24 cm) construction tubes must not exceed 3 ft. (0.91 m) above grade.
  - c) The maximum tube height for the 8 in. (20.30 cm) construction tubes must not exceed 4 ft. (1.22 m) above grade and braced.
  - d) The maximum tube height for the 10 in. (25.40 cm) and 12 in. (30.48 cm) construction tubes must not exceed 8 ft. (2.44 m) above grade and must be braced.
  - e) The maximum tube height for the 12in (30.48 cm), 14in (35.56 cm), 16in (40.64 cm) and 18in (45.72) construction tubes, must not exceed 8 ft. (396.24 cm) above grade and must be braced.
  - f) Backfill must not exceed 5 ft. (1.52 m).
8. When ready to pour use another Bigfoot footing form inverted on top of the construction tube to act as a funnel.

## 2.0 CONSTRUCTION TUBE PIERS

Construction tubes exceeding 8 ft. (2.44 m) in height above grade must be approved by a Professional Engineer and require external vibration. Place “top of concrete” grade line with piano wire to designed height of the piers from the batter boards.

With *Above Ground Applications* loosely place construction tube on the collar of the Bigfoot Systems® Footing Form and mark the concrete level. Remove the construction tube, mark the concrete level with a wrap-around template and saw off the excess construction tube squarely. If the construction tube frays inward when cut with a handsaw, remove excess frayed tube material with a utility knife for ease of application. Lay construction tube on a level area and attach four 1 in. (2.54 cm) x 3 in. (7.62 cm) x 8 in. (20.32 cm) scab boards on the top of the construction tube on the outside at four quarter points, with two or more screws from inside the construction tube walls (See Drawing BFS-103). Place the construction tube on the Bigfoot Systems® Footing Form collar and attach with a minimum of four 3/4 in. to 1 in. long (19.1 mm - 2.54 cm) wood screws. Place and screw the four bracing boards to the top of the pier scab boards and to the four “2 x 4” anchor stakes. (See Drawing BFS-103) Level and plumb the pier, check the “top of concrete” level mark, adjust if necessary, attach and secure the bracing boards. RE-CHECK!! Then fasten the Bigfoot to the ground as detailed in Section 1.1 (Items 4 and 5) “Above Ground Application.”

Model BF36 is not recommended for above ground applications.

With *Below Grade Applications* pre-attach the construction tube to the Bigfoot Systems® Footing Form with a minimum of four 3/4 in. - 1 in. long (19.1 mm - 2.54 cm) wood screws, and lower into the excavated

hole. Level, plumb and mark the concrete level on the construction tube. Use a minimum of six ¾ in. – 1 in. long (19.1mm – 25.4mm) wood screws, evenly spaced around the diameter of the Bigfoot when using the Model BF36. Remove the Bigfoot from the hole and lay the construction tube on supports. Mark the concrete level with a wrap-around template and saw off the excess construction tube squarely. If the construction tube frays inward when cut with a handsaw, remove excess frayed tube material with a utility knife for ease of application. Attach the four 1 in. (2.53 cm) x 3 in. (7.62 cm) x 8 in. (20.32 cm) scab boards on the top of the construction tube on the outside at four quarter points, with two or more screws from inside the tube walls. (See drawing BFS-103) Carefully replace the assembled unit in the excavated hole, check for level, plumb, “top of concrete” level mark and then backfill as detailed in Section 4.0 “Backfill for Below Grade Applications.”

### 3.0 BRACING (DRAWING BFS-103)

Brace the construction tube with four framing boards at the top and nail to stakes and scab boards. Brace the top of construction tubes to each other with spreaders attached to the braces or the scab boards.

### 4.0 BACKFILL FOR BELOW GRADE APPLICATIONS

For the BF20, BF24, and BF28, place backfill a minimum of 2 ft. (0.61 m) to a maximum of 5 ft. (1.52 m) from the bottom of the footing form as shown in Drawing BFS-102. Backfill should be consolidated with a hand tamper or a “2 x 4” on end.

For the BF36 place backfill a minimum of 3 ft (0.915 m) to a maximum of 5 ft. (1.52 m) from the bottom of the footing form. Backfill should be consolidated with a plate tamper.

Do not strike Bigfoot Systems® Footing Forms with tamper. Re-check alignment of pier. Do not over consolidate so as to distort the shell of the footing form. The backfill is intended to hold the footing form in place.

### 5.0 PLACING CONCRETE

Concrete shall have a minimum of 3000 psi (20.7 Mpa) 30-day compressive strength and consist of not more than ¾ in. (19.05 mm) aggregate and a slump of 3” (75 mm) to 6” (150 mm). Place concrete in 10 in. - 16 in. (25.40 cm - 40.64 cm) lifts and ‘rod’ or probe concrete with a 2 x 4 or steel bar 10 to 12 thrusts per lift or use a concrete vibrator to consolidate the concrete. Do not strike inside the top lip of the Bigfoot footing form when rodding the first lift of concrete - rod in the center area, NOT around the perimeter. Finish pouring concrete in equal lifts and rod to the perimeter of the construction tube surface. Place three to four #4 or #5 rebar in the construction tube extending approx. 6 in. (15.24 cm) below the bottom ring of the footing form. When placing rebar, keep approximately 2 in. (5.08 cm) from the side of the construction tube. Level concrete at the top of the construction tube, screen off, and place the anchor plate or anchor bolts as specified. Re-check alignment or piers and move to re-align and re-secure braces as necessary before concrete sets.

## 6.0 STRIPPING OF FORMS

Stripping of the plastic footing form is not necessary with the Bigfoot Systems® Footing Form. Remove wooden braces, cut and remove construction tube 4 in. (10.16 cm) below the finished grade. If the footing form should need to be removed, use form oil inside the footing form before pouring concrete. If removal of tube is necessary after concrete is poured this should then be done within 24 - 48 hours for best results.

## 7.0 STRUCTURAL STEEL

If structural steel is required it must be designed by a qualified professional engineer in accordance with the Building Codes.

## 8.0 SPACING OF FOOTING

Spacing of the footing forms is dependent on loads, number of stories, and joist span. Footing design and spacing should follow the current provincial or territorial building code for Canada and the Federal Building Code for the United States.

## 9.0 LOADS FOR BIGFOOT SYSTEMS® FOOTING FORMS

Allowable loads for the various footing forms can be found at Table BFS-101 for Canadian applications and Table BFS-102 for American applications.

Bigfoot Systems Inc.  
RR#2, Mahone Bay  
6750 Hwy. #3, Martins Point  
Nova Scotia, CANADA  
B0J 2E0  
Toll Free: 1-800-934-0393  
Phone: 1-902-627-1600  
Fax: 1-902-627-1700  
E-mail: [info@bigfootsystems.com](mailto:info@bigfootsystems.com)  
Web-site: [www.bigfootsystems.com](http://www.bigfootsystems.com)

November 2024  
Revision 1

**TABLE BFS-T102  
UNITED STATES**

**Allowable Gravity Loads on BIGFOOT Systems® Footing Forms  
Models BF20, BF24, BF28 and BF36**

Soil Description	Allowable Soil Bearing Pressure psf (kPa)	Model BF20 Allowable Loads lbs (kN)	Model BF24 Allowable Loads lbs (kN)	Model BF28 Allowable Loads lbs (kN)	Model BF36 Allowable Loads lbs (kN)
Clay, Sandy Clay, Silty Clay and Clayey Silt	2000 (95.76)	4364 (19.4)	6283 (27.9)	8560 (38.1)	14134.50 (62.82)
Sand, Silty Sand Clayey Sand Silty Gravel, and Clayey Gravel	3000 (143.64)	6546 (29.1)	9425 (41.9)	12840 (57.1)	21201.75 (94.23)
Sandy Gravel or Gravel	5000 (239.40)	10910 (48.5)	15,708 (69.9)	21400 (95.2)	35336.25 (157.05)
Sedimentary Rock	6000 (287.28)	13092 (58.2)	18,850 (83.8)	25680 (114.2)	42403.50 (188.46)
Crystalline Bedrock	12,000 (574.56)	26184 (116.5)	37,699 (167.7)	51360 (228.4)	84804.75 (376.91)

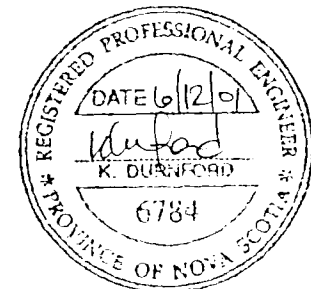



Notes:

- 1) *The allowable gravity loads shown meet or exceed the requirements of the Canadian National Building Code, Section 9.4.4.1.*
- 2) *Minimum concrete compressive strength shall be 3000 psi (20.7 MPa) at 28 days.*
- 3) *Calculations are in accordance with CSA A23.3-M77 which is equivalent to ACI 318.95.*
- 4) *Gravity loads include only dead loads (weight of construction materials) and service loads such as snow loads and rain loads. Pier design and their ability to resist lateral and uplift loads is beyond the scope of this table.*
- 5) *Piers requiring design for earthquake loads shall be designed by a qualified Professional Engineer.*
- 6) *Maximum lift when pouring concrete is 16" (40.6 cm)*
- 7) *Allowable loads shown are for use in the U.S. and are based on soil bearing pressure values provided by BOCA. Canadian users should refer to table BFS-T101, (Canada).*
- 8) *Bigfoot Systems® Footing Forms are not intended as a substitute foundation system for the full foundations commonly used under residential housing unless they have been designed to do so by a qualified professional engineer.*

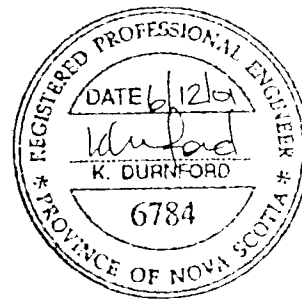
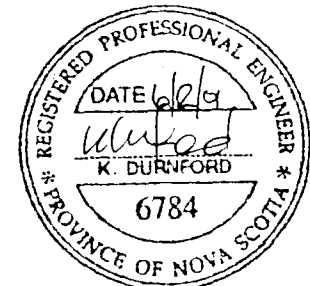

TABLE BFS-T101  
CANADA

Allowable Loads on BIGFOOT Systems® Footing Forms  
Models BF 20, BF24, BF28 and BF36

Soil Description	Allowable Soil Bearing Pressure psf (kPa)	Model BF 20 Allowable Loads lbs (kN)	Model BF24 Allowable Loads lbs (kN)	Model BF28 Allowable Loads lbs (kN)	Model BF36 Allowable Loads lbs (kNs)
Soft Clay	835.60 (40.00)	1823.28 (8.1)	2624.6 (11.7)	3573.0 (15.9)	5913 (26.28)
Loose Sand or Gravel*	1044.50 (50.00)	2279.10 (10.1)	3280.8 (14.6)	4466.3 (19.9)	7391 (32.85)
Firm Clay*	1566.75 (75.00)	3418.65 (15.2)	4921.2 (21.9)	6699.4 (29.8)	11085 (49.27)
Compact or Dense Silt*	2089.00 (100.00)	4558.20 (20.3)	6561.6 (29.2)	8932.6 (39.7)	14782 (65.70)
Dense or Compact Sand or Gravel*	3133.50 (150.00)	6837.3 (30.4)	9842.3 (43.8)	13398.8 (59.6)	22174 (98.55)
Stiff Clay*	3133.50 (150.00)	6837.3 (30.4)	9842.3 (43.8)	13398.8 (59.6)	22174 (98.55)
Glacial Till	4178.00 (200.00)	9116.4 (40.5)	13123.1 (58.4)	17865.1 (79.5)	29565 (131.40)
Clayey Shale	6267.00 (300.00)	13674.6 (60.8)	19712.9 (87.7)	26797.7 (119.2)	44347 (197.10)
Sound Bedrock	10455.00 (500.00)	22812.8 (101.5)	32839.2 (146.1)	44705.6 (198.9)	73912 (328.50)



*Notes:*

- 1) *The allowable loads shown meet or exceed the requirements of the National Building Code, Section 9.4.4.1.*
- 2) *\* most common range of soils*
- 2) *Minimum concrete compressive strength shall be 3000 psi (20.7 MPa) at 28 days.*
- 3) *Calculations are in accordance with CSA A23.3-M77 which is equivalent to ACI 318.95.*
- 4) *Gravity loads include only dead loads (weight of construction materials) and service loads such as snow loads and rain loads. Pier design and their ability to resist lateral and uplift loads is beyond the scope of this table.*
- 5) *Piers requiring design for earthquake loads shall be designed by a qualified Professional Engineer.*
- 6) *Maximum lift when pouring concrete is 16" (40.6 cm)*
- 7) *Bigfoot Systems® footing forms are not intended as a substitute foundation system for the full foundations commonly used under residential housing unless they have been designed to do so by a qualified professional engineer.*

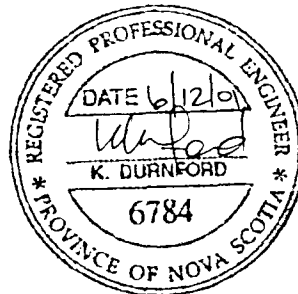

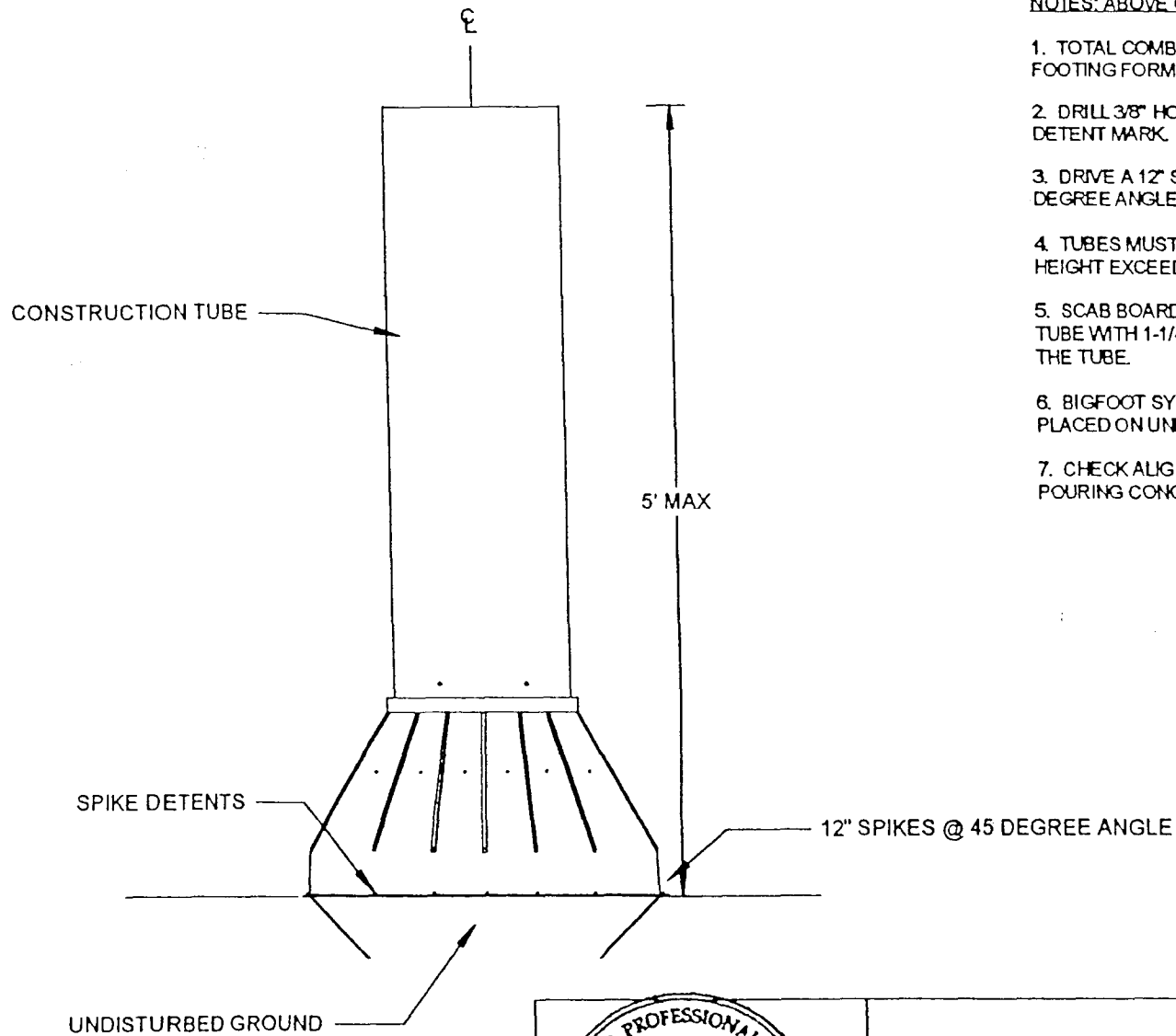

**NOTES: ABOVE GROUND APPLICATION**

1. TOTAL COMBINED HEIGHT OF BIGFOOT SYSTEMS® FOOTING FORM MUST NOT EXCEED FIVE FEET (5).
2. DRILL 3/8" HOLE AT A 45 DEGREE ANGLE AT EACH DETENT MARK.
3. DRIVE A 12" SPIKE THROUGH 3/8" HOLE AT A 45 DEGREE ANGLE INWARDS.
4. TUBES MUST BE BRACED ONCE THE COMBINED HEIGHT EXCEEDS THREE FEET (3) ABOVE GROUND.
5. SCAB BOARDS ARE FASTENED TO THE CONSTRUCTION TUBE WITH 1-1/4" WOOD SCREWS FROM THE INSIDE OF THE TUBE.
6. BIGFOOT SYSTEMS® FOOTING FORMS MUST BE PLACED ON UNDISTURBED GROUND.
7. CHECK ALIGNMENT OF CONSTRUCTION TUBE BEFORE POURING CONCRETE.

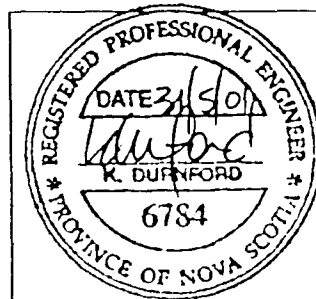

DRAWN: KD

DATE: 4 OCT 99

**BIGFOOT SYSTEMS® FOOTING FORM**

TITLE

**ABOVE GROUND APPLICATION**

SIZE	CAGE CODE	DWG NO	REV
A		BFS-101	
SCALE	SHEET		
1" = 1'	1 of 1		

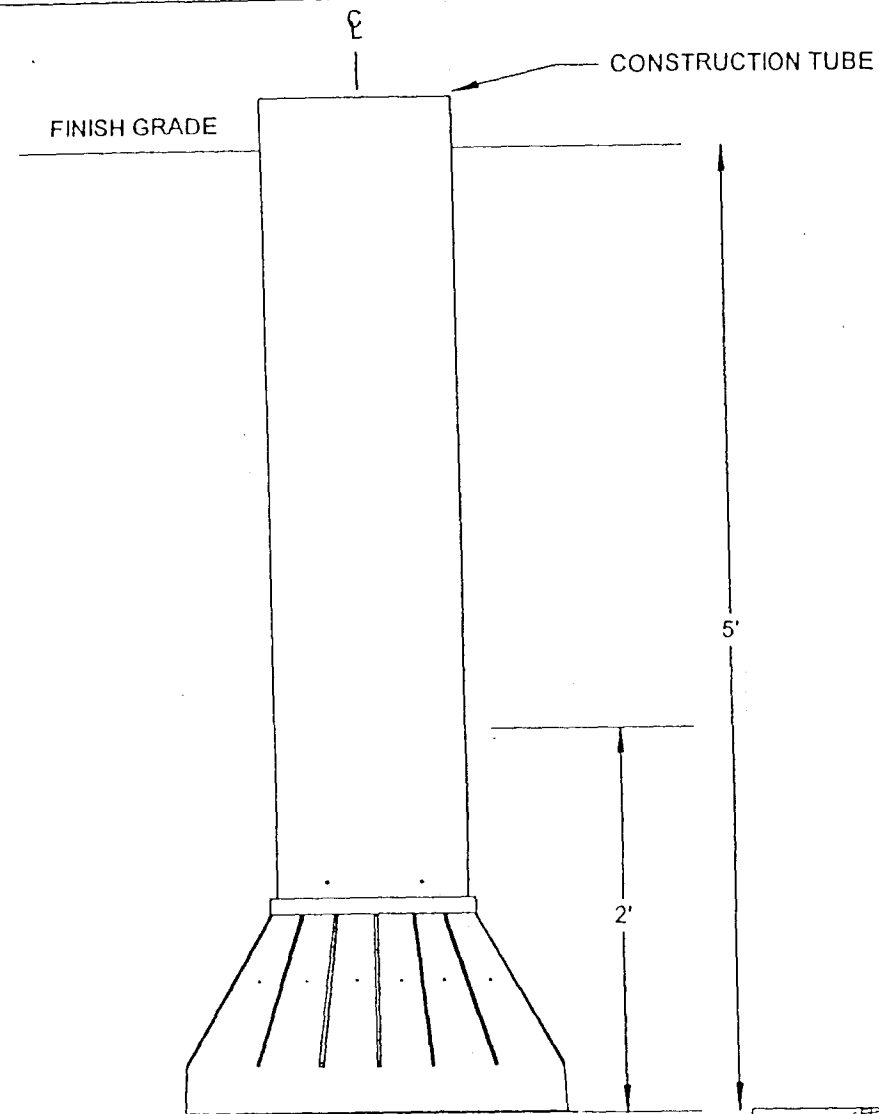

UNDISTURBED GROUND OR  
4" - 6" COMPACTED GRAVEL

**NOTES: BELOW GRADE APPLICATION**

1. THE TOTAL COMBINED HEIGHT OF BIGFOOT SYSTEMS® FOOTING FORM MUST NOT EXCEED THIRTEEN FEET (13').
2. SCREW CONSTRUCTION TUBE TO FOOTING FORM WITH A MINIMUM OF FOUR (4) 3/4" #8 WOOD SCREWS.
3. BIGFOOT SYSTEMS® FOOTING FORMS MUST BE PLACED ON UNDISTURBED GROUND OR 4" - 6" COMPACTED GRAVEL.
4. BACKFILL MUST BE PLACED UP TO A MINIMUM OF 2' TO A MAXIMUM OF 5' FROM THE BOTTOM OF THE FOOTING FORM. THE BACKFILL IS INTENDED TO HOLD THE FOOTING FORM IN PLACE.
5. BACKFILL SHOULD BE CONSOLIDATED WITH A MANUAL PLATE TAMPER OR A "2 X 4" ON END. DO NOT STRIKE BIGFOOT SYSTEMS® FOOTING FORM. DO NOT OVER CONSOLIDATE SO AS TO DISTORT THE SHELL OF THE FOOTING FORM.
6. CHECK ALIGNMENT OF CONSTRUCTION TUBE AFTER BACKFILLING.

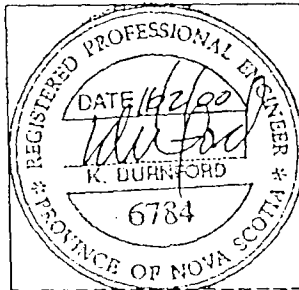

DRAWN: KD

DATE: 16 FEB 2000

**BIGFOOT SYSTEMS® FOOTING FORM**

TITLE

BELOW GRADE APPLICATION

SIZE <b>A</b>	CAGE CODE	DWG NO <b>BFS-102</b>	REV <b>1</b>
SCALE <b>1" = 1'</b>	SHEET <b>1 OF 1</b>		

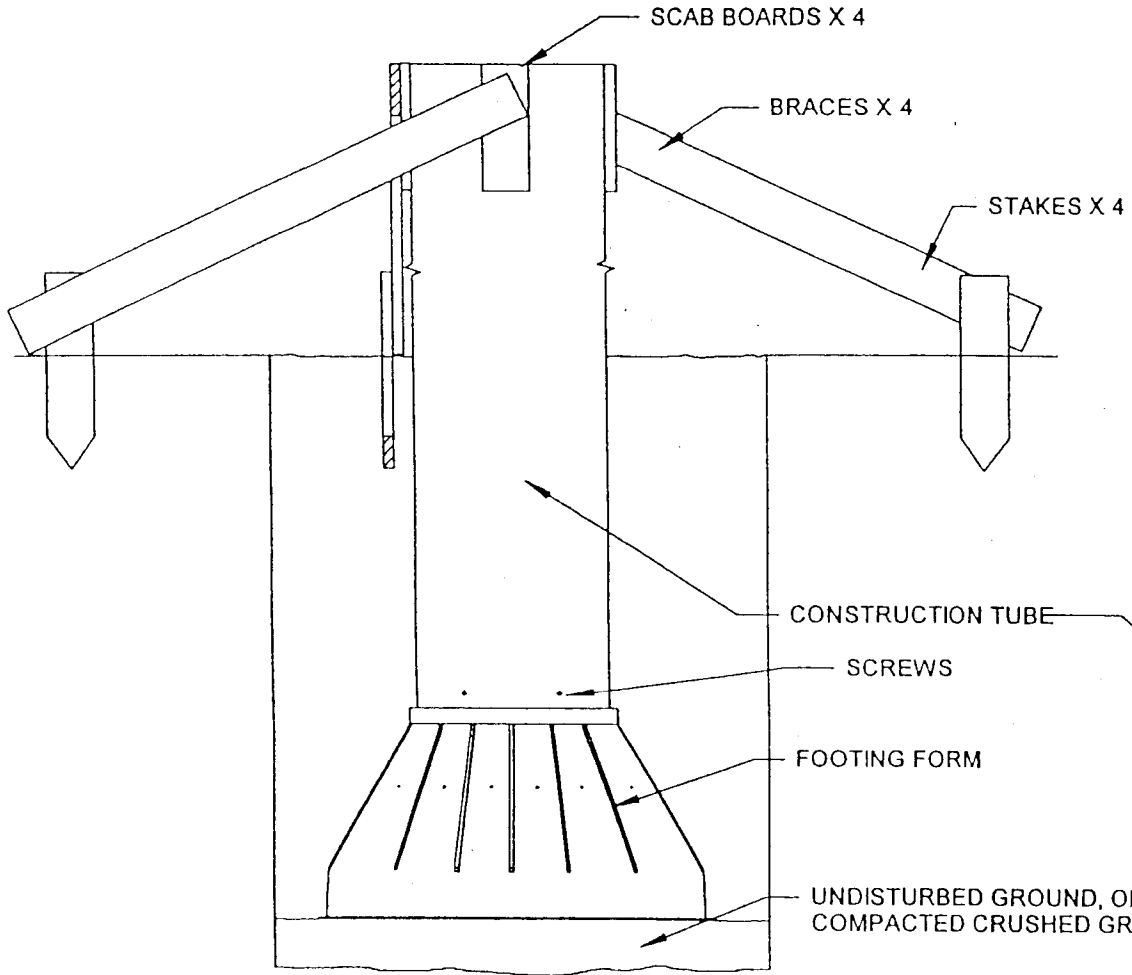

NOT TO SCALE

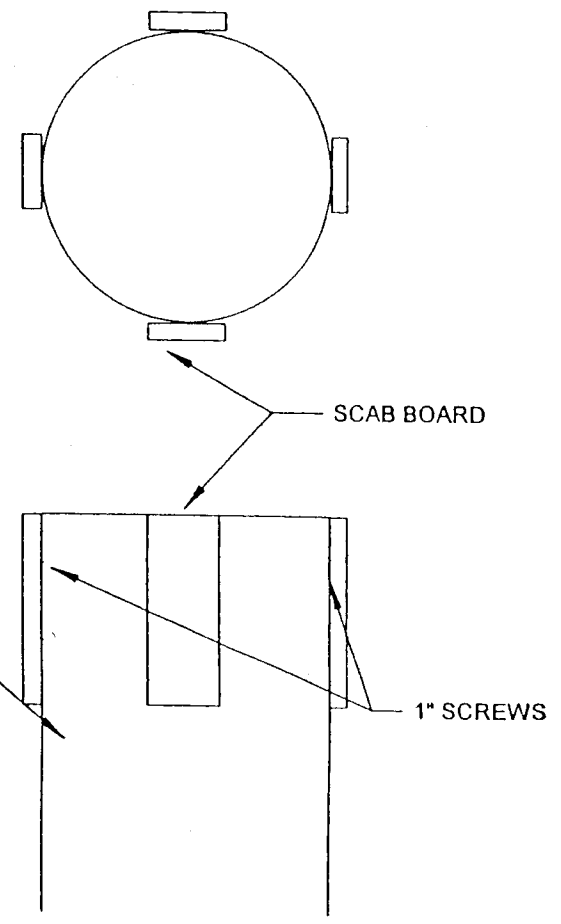

SCALE: 1" = 8"

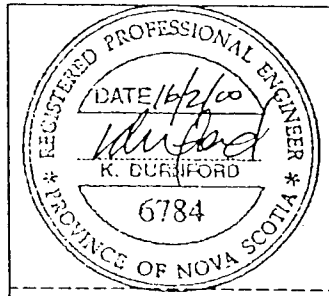

DRAWN: KD

DATE: 18 FEB 2000

BIGFOOT SYSTEMS<sup>®</sup> FOOTING FORM

TITLE			
BRACING			
SIZE	CAGE CODE	DWG NO	REV
A		BFS-103	1
SCALE		SHEET	
AS SHOWN		1 OF 1	